

KF 804

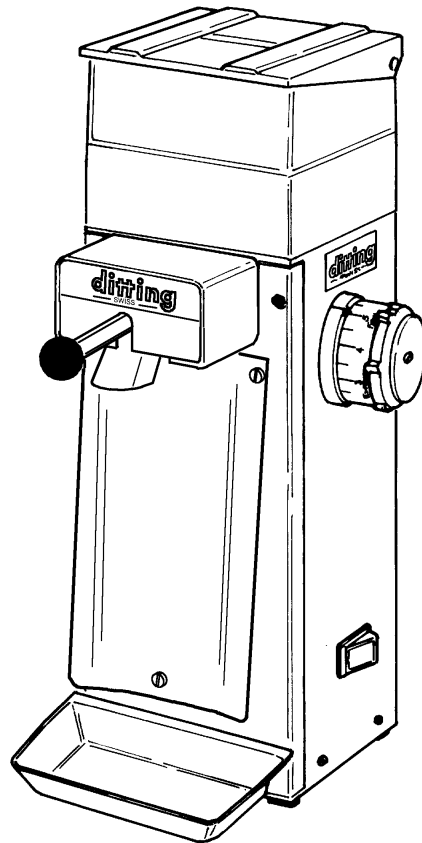

KR 804

**TYPE**

**Voltage**

**Manuf. no.**

Your service centre .....

.....

.....

.....

.....

## Contents

	page	
<b>1</b>	<b>General</b>	
1.1	Warranty information	3
1.2	Transfer declaration	4
1.3	General safety instructions	5
1.3.1	Information and safety symbols	6
<b>2</b>	<b>Installation of coffee grinder</b>	
2.1	Description and installation of unit	6
2.2	How to use the coffee grinder	7
<b>3</b>	<b>Care / Maintenance / Adjustment</b>	
3.1	Care and cleaning of the coffee grinder	8
3.2	Maintenance	8
3.3	Setting the scale (adjustment)	8
3.3.1	Basic setting (calibration)	9
3.3.2	Changing the scale setting (customer setting)	10
3.4	Replacing the grinding discs	11
<b>4</b>	<b>Faults / action</b>	
4.1	Action in event of a fault	12
4.1.1	Table with possible malfunctions	12
4.2	Repairs	13
4.2.1	Unblocking the discharge tube	13
4.2.2	Unblocking the grinding unit	13
4.2.3	Replacing the rubber bolt	14
4.2.4	<i>Circuit breaker (option)</i>	14
<b>5</b>	<b>Customer service</b>	15

## 1 General

Dear Customer,

We congratulate and thank you for purchasing a DITTING quality product. These operating instructions have been prepared to simplify your use of the coffee grinder. They contain information, advice and instructions for the best use of your unit.

### 1.1 *Warranty information*

**ALTHOUGH YOUR COFFEE GRINDER IS DISTINGUISHED BY A HIGH QUALITY AND SAFETY STANDARD, DAMAGE TO MATERIAL OR RISK OF INJURY CANNOT BE EXCLUDED IF OPERATED INCORRECTLY, USED IMPROPERLY OR MISUSED.**

**THE OPERATING INSTRUCTIONS WILL THEREFORE FAMILIARISE YOU WITH CORRECT USE OF THE COFFEE GRINDER AND ASSIST YOU TO AVOID WRONG OPERATIONS. IF THE ENCLOSED INSTRUCTIONS ARE FOLLOWED EXACTLY, YOU WILL AVOID DANGERS, REDUCE REPAIR AND STOPPAGE TIMES AND INCREASE THE RELIABILITY AND SERVICE LIFE OF YOUR UNIT.**

**TO ENSURE THAT YOU AND YOUR EMPLOYEES TAKE NOTICE OF THE CONTENTS OF THE OPERATING INSTRUCTIONS AND FOR YOUR OWN SAFETY, WE WOULD ASK YOU TO COMPLETE THE TRANSFER DECLARATION PRINTED ON THE FOLLOWING PAGE, DETACH THIS ALONG THE PERFORATION AND RETURN IT TO YOUR DEALER.**

## 1.2 Transfer declaration

### To ensure transfer of the operating instructions to final consumers

**Note:** The following declaration should be completed by the dealer and the purchaser. The purchaser undertakes to return this declaration to the dealer. The purchaser thereby certifies that the dealer has drawn his attention to the contents of operating instructions no. 64400, in particular to the relevant safety instructions for use of the machine.

64400 C 03/20

page 4 - 15

#### Transfer declaration

(1) Type

Machine no.

(2) Address of customer

(3) The machine specified in (1) was purchased by me. The complete operating instructions were handed to me with transfer of the machine.

\_\_\_\_\_  
Signature of customer

\_\_\_\_\_  
Place / date

(4) Date of transfer

(5) Address of dealer/importer

\_\_\_\_\_  
Company stamp/signature

(6) The machine was handed to the customer in accordance with the guidelines of the manufacturer.

Company stamp/signature if not identical with (5)

\_\_\_\_\_  
Signature of customer service-  
specialist

\_\_\_\_\_  
Date

## 1.3 General safety instructions





- The operating instructions must be kept permanently at the place of operation of the machine and if possible attached at the point of installation in the immediate vicinity of the machine.
- The competent sales and service personnel must have read the operating instructions before putting the coffee grinder into operation and be familiar with all functions including action in the event of a fault.
- If customers themselves operate the machine, a notice must be placed clearly visible in the immediate vicinity of the machine that customers must immediately call the service personnel responsible in the event of a fault and not try to eliminate the fault themselves by tampering with the machine.
- The machine must be placed in the sales areas so that the sales personnel responsible can be reached by the customer without difficulty.
- Only original spare-parts must be used for repairs to the grinder. If spare-parts from other manufacturers are used, the serviceability of the grinder may be impaired. In addition, further injury to persons or material damage cannot be excluded.
- The grinder should be installed out of reach of children. Children and users must on no account reach into the openings or come into contact with electrical components.
- Only original grinding discs sharpened by DITTING must be used.
- Never reach into the hopper opening while the machine is running.
- Never touch electrical components with conducting objects, such as needles, pins, cutlery, etc. !
- The emission value referred to the workplace is 76 dB(A).
- The machine must be electrically protected by fuses according to the nameplate and the local regulations.



## 1.3.1 Information and safety symbols

Two information symbols are used in these operating instructions to emphasise important c

	<b>Information</b> This symbol indicates information containing important data concerning efficient use. Non-observance can lead to faults.
	<b>Safety</b> This symbol indicates information which if not observed can lead to danger to persons and/or substantial material damage. The safety instructions must be followed without fail.

## 2 Installation of coffee grinder

### 2.1 Description and installation of unit

The **KF/R 804** coffee grinders are suitable for grinding various kinds of coffee. The grinding fineness can be set from "Turkish fine" to "coarse" with an adjusting knob provided with a scale. The **KF/R 804** coffee grinders are suitable for use in small food stores, cafés, restaurants and hotels. The simple method of operation enables customers to use the grinder themselves in self-service stores. Operation of the machine can differ slightly from the description in these operating instructions depending on the version KF or KR.

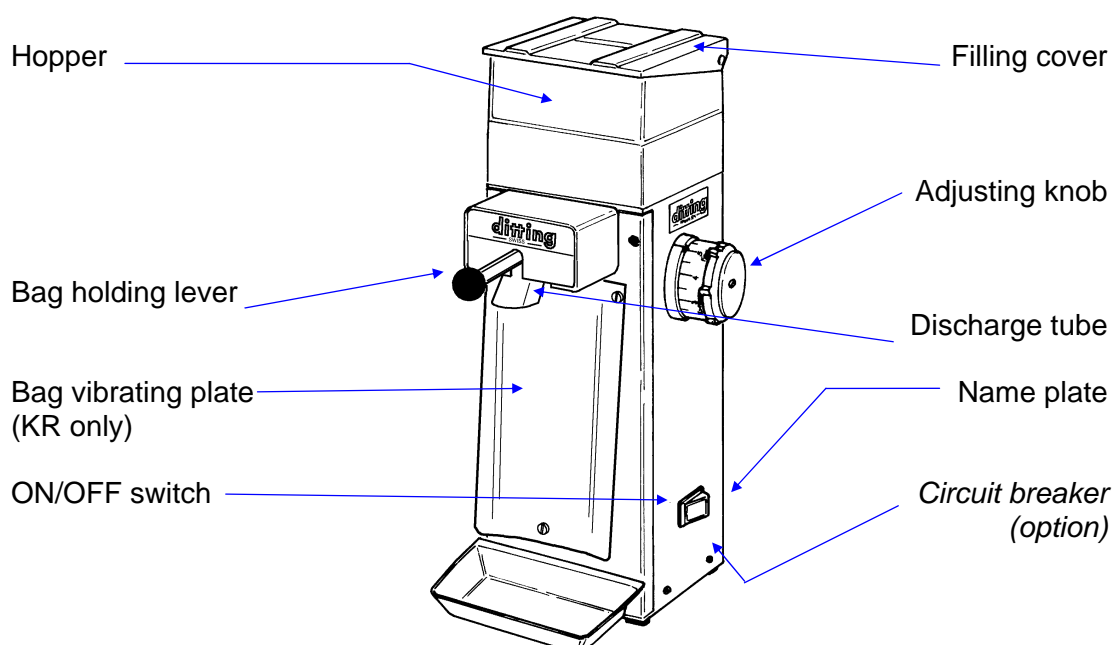

	<p>The grinder must only be installed in dry areas! Place the coffee grinder on a firm, level and non-slip base. Danger of tipping and slipping on unstable surfaces. Before connecting the coffee grinder to the mains supply, ensure that this supply corresponds with the data on the unit nameplate.</p>
---	--

## 2.2 How to use the coffee grinder

- Set the required grinding fineness on the scale with adjusting knob **(1)**.
- Open the filling cover **(2)** and place coffee beans in hopper **(3)**.
- Clamp empty paper bag over discharge tube **(5)** with bag holding lever **(4)** and release bag.

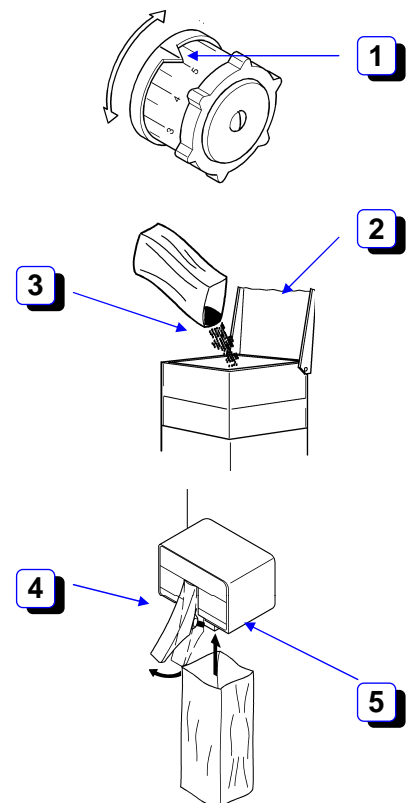

Please ensure that the bag is opened fully before clamping with bag holding lever **(4)** for grinding.

Reason: If the bag is not fully open, the ground coffee cannot run out properly, which can result in a build-up and malfunction of the unit.

- Switch on motor with the ON/OFF switch **(6)**.
- After the end of grinding switch off the motor **(6)**.
- Hold the bag tightly in the hand and tap the discharge tube clean by pulling and releasing the bag holding lever **(4)**, then remove the bag.

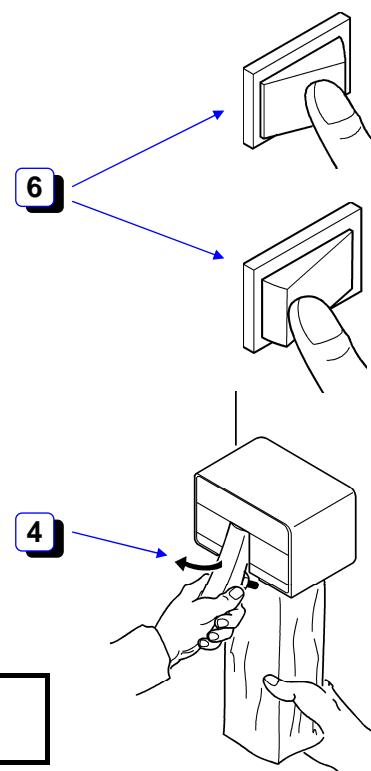

Only grind whole coffee beans!  
Coffee already ground must not be ground again!

## 3 Care / maintenance / adjustment

### 3.1 Care and cleaning of the coffee grinder



The coffee grinder must only be cleaned with a dry cloth.  
Do not use an alkaline cleaning agent.  
Do not spray coffee grinder with water and/or steam.

Reason: It can result in a short-circuit and therefore damage to the unit. The use of alkalis can affect the flavour of the coffee.

The coffee grinder should be cleaned at least once weekly and always if soiled.

### 3.2 Maintenance

If the grinding quality is no longer of the required standard, the grinding discs must be replaced.

The grinding discs should be inspected for wear after not longer than 12 months.



Periodic checking of the grinding quality and grinding discs must only be performed by competent specialists and/or service personnel.

### 3.3 Setting the scale (adjustment)

Setting of the scale (with the adjusting knob) makes the fineness of the ground coffee correspond with the fineness set on the scale (marked).



Setting of the scale must only be performed by persons familiar with the unit after carefully reading the following instructions.

The basic setting according to 3.3.1 should be made:

- following change of grinding discs
- following inadvertent displacement of the scale setting

Change of scale setting as 3.3.2 should be performed:

- if the desired grinding fineness does not correspond with the scale (adjusting knob)
- if an individual setting of the grinding fineness is desired (customer setting)

## 3.3.1 Basic setting (calibration)



If the basic setting is incorrect, friction can occur between the grinding discs, resulting in excessive wear.

- Switch on motor.
- Unscrew screw **(1)** at centre of adjusting knob **(2)** approx. 3 - 5 mm, do not remove.
- Pull out **(3)** adjusting knob **(2)** and turn 1/4 of a revolution anti-clockwise **(4)**. Release and engage **(5)** adjusting knob **(2)**. (1 division corresponds to approx. 3 - 4 mm on the scale.) Turn adjusting knob **(2)** slowly clockwise to scale position 1 until there is a sound of grinding discs rubbing together **(6)**.
- When the sound of grinding discs rubbing together is heard, turn back while locked 10 mm anti-clockwise **(7)**. Pull out **(8)** adjusting knob **(2)** and turn clockwise to scale position 1 **(9)**. Release adjusting knob **(2)** and engage **(10)**.
- Retighten screw at centre of adjusting knob **(2)**.

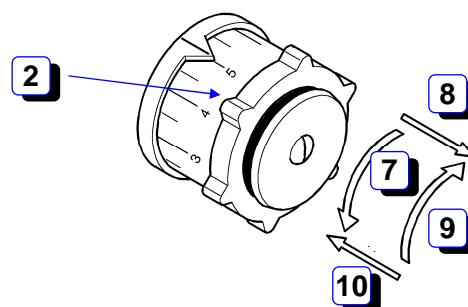
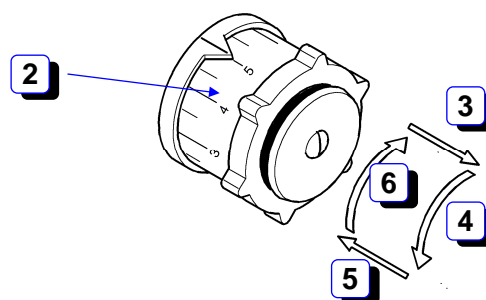
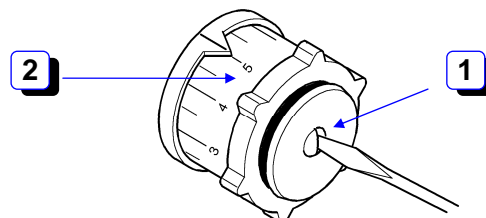

### Checking the setting:

When turning the adjusting knob from scale position 1 - 9 there must on no account be a sound of metal parts rubbing together.



There must be **no sound** of grinding discs rubbing together at scale position 1 = excessive wear of grinding discs.

- Switch off motor.

## 3.3.2 Changing the scale setting (adjustment for customer settings)

- Switch off motor.
- Unscrew screw **(1)** at centre of adjusting knob **(2)** approx. 3 - 5 mm, do not remove.
- Set required number of divisions by pulling out adjusting knob **(2)**, turning in the corresponding direction and re-engaging. (1 division corresponds to approx. 3 - 4 mm on the scale.)
  - adjustment clockwise = coarser grinding
  - adjustment anti-clockwise = finer grinding
- Switch on motor.
- Retighten screw at centre of adjusting knob **(2)**.

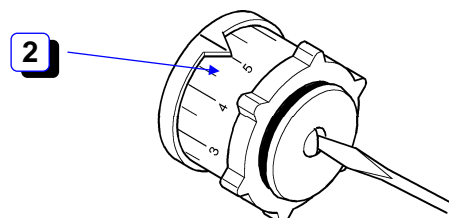
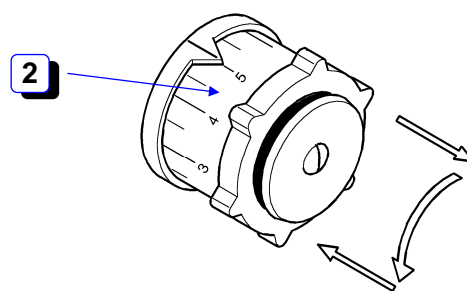
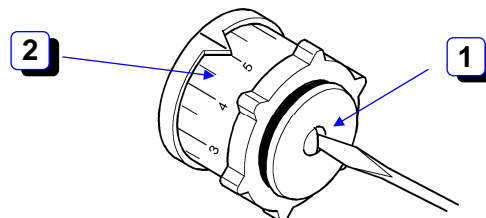

	<p><b>Checking the setting:</b> When turning the adjusting knob from scale position 1 - 9 there must on no account be a sound of metal parts rubbing together.</p>
	<p>There must be <b>no sound</b> of grinding discs rubbing together at scale position 1 = excessive wear of grinding discs. If there is a sound, grinding must be set more coarsely (see 3.3.1).</p>

- Switch off motor.



Before changing grinding discs **switch off motor** without fail and **disconnect power cable** !

The grinding discs must only be replaced by persons familiar with operation of the machine according to the following instructions.

- Switch off motor and pull out power cable. Set adjusting knob **(2)** to coarse grinding scale position 9.
- Release left-hand hopper lock **(3)** only, but do not remove. Turn hopper **(4)** counter-clockwise through approx. 15° and remove.
- Remove stationary disc flange **(5)** by releasing screws **(6)** (see illustration) and dismantle grinding discs. Dismantle lower grinding disc from rotating disc flange (**rotary flange 7**).

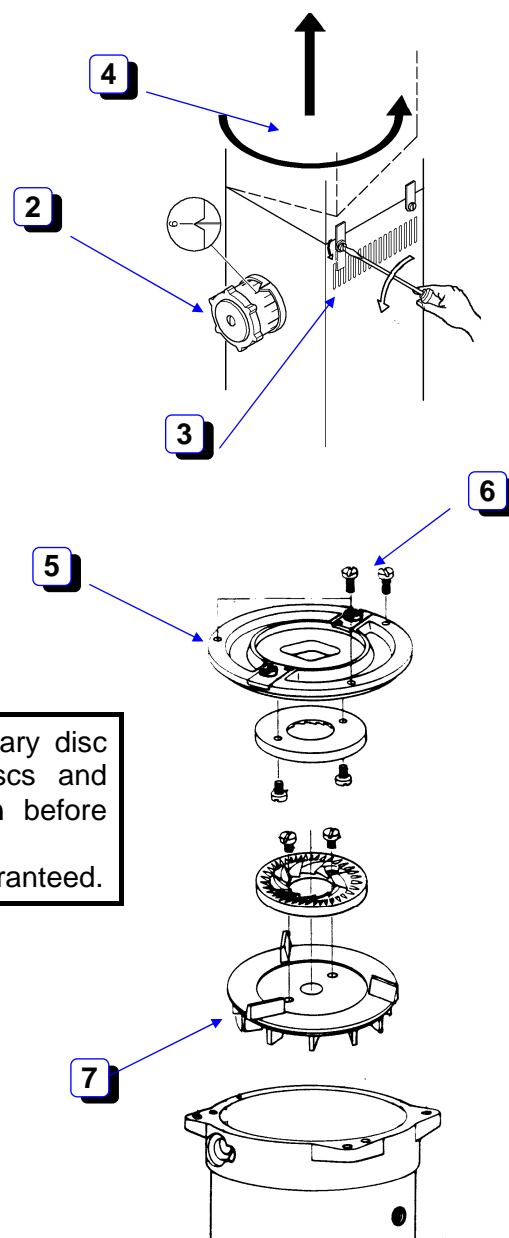



All supporting (mating) surfaces of stationary disc flange, rotating disc flange, grinding discs and grinding case must be **absolutely clean** before assembly.

Only in this way can perfect grinding be guaranteed.

- Screw **new grinding** discs to the cleaned stationary and rotating disc flanges **(5 + 7)**.
- For **resharpened grinding discs** the shims if supplied should be inserted between grinding disc and flange.
- Then re-assemble parts in reverse sequence.

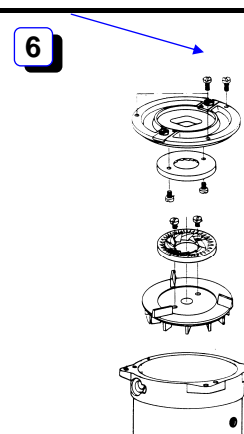
- Plug in power cable, switch on coffee grinder briefly. If it blocks or there is a sound of metal parts rubbing together, the scale setting must be adjusted *according to 3.3.2*.
- Retighten screws **(6)** of the stationary disc flange. For this purpose the hopper **(4)** must be removed again and then re-fitted.





Retighten hopper lock **(3)** after reassembly (see illustration page 11).

- Perform basic setting (calibration) *according to 3.3.1*.

## 4 Faults / action

### 4.1 Action in event of a fault



When operated by customers, it must be ensured that personnel are notified in the event of a fault and that customers do not try to repair the machine themselves.  
The grinder must only be opened, inspected and dismantled by persons familiar with the method of operation of the machine, who have previously read these operating instructions through carefully.

#### 4.1.1 Table with possible malfunctions

Fault	Result	Action (information text)	Re.
Grinder cannot be switched on	ON/OFF switch does not light Circuit breaker	Check power cable, connection and building fuses Reset circuit breaker	4.2.4
Grinder jams, motor does not start	ON/OFF switch lights	Unblock discharge tube Unblock grinding unit	4.2.1 4.2.2 4.2.4
Irregular grinding		Check grinding discs for wear and replace if necessary	3.4
Increased amount of dust		Check grinding discs for wear and replace if necessary	3.4
Bag slips or is no longer held properly		Replace rubber bolt	4.2.3

## 4.2 Repairs

	<p><b>Switch off motor and pull out power cable</b> before all major repairs requiring work inside the machine, in order to avoid danger of injury while working on motor while running and electric shock !</p>
	<p>The electrical wiring diagram for this unit can be found inside the front panel.</p>

### 4.2.1 Unblocking the discharge tube

- Switch off motor and pull out power cable.
- Unblock discharge tube from outside as far as possible.
- Set adjusting knob **(1)** to coarse grinding scale position 9 and switch motor on again. This frequently unblocks the grinder and extracts any foreign bodies in the grinding unit.
- If the motor still does not run, continue according to 4.2.2.

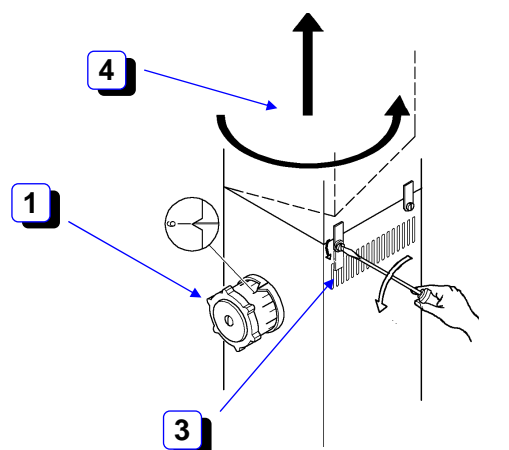

### 4.2.2 Unblocking the grinding unit

- Switch off motor and pull out power cable.
- Remove coffee beans from hopper **(4)** (use a vacuum cleaner if necessary).
- Release left-hand hopper lock **(3)** only, but do not remove. Turn hopper **(4)** counter-clockwise through approx. 15° and remove.
- Remove stationary disc flange **(5)** by releasing screws **(6)** (see illustration).

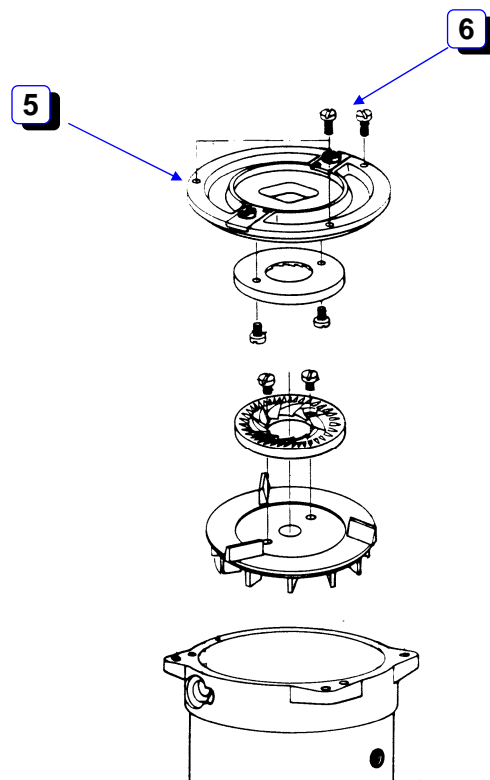

- Remove foreign bodies. Check grinding discs, rotating and stationary disc flange, etc. for damage.



All supporting surfaces of stationary disc flange, rotating disc flange, grinding discs and grinding case must be **absolutely clean** before assembly. Only in this way can perfect grinding be guaranteed.

- Then re-assemble parts in reverse sequence.
- Plug in power cable, switch on coffee grinder briefly.



If the coffee grinder should block or there is a sound of metal parts rubbing together, the scale setting must be adjusted *according to 3.3.2*.

- Retighten screws **(6)** of the stationary disc flange. For this purpose the hopper **(4)** must be removed again and then re-fitted (see illustration page 13).



Retighten hopper lock **(3)** after reassembly (see illustration page 13).

- Perform basic setting (calibration) *according to 3.3.1*.

#### 4.2.3 Replacing the rubber bolt (KF only)

- Pull bag holding lever **(1)**.
- Remove sleeve screw **(2)** with adequate wrench (no. 17).
- Replace old rubber tube **(3)** with new one.
- Re-tighten sleeve screw **(2)** with adequate wrench and release bag holding lever.

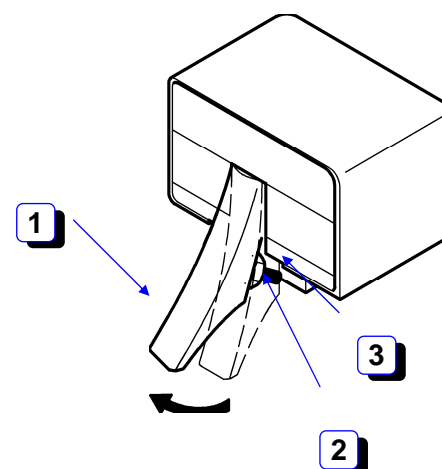

#### 4.2.4 Circuit breaker

- Set ON/OFF switch to position 0.
- Close overcurrent release by pressing red button underneath bottom plate.
- The coffee grinder is again ready for operation.

## 5 Customer service

If it is found during maintenance that the grinding discs must be resharpened/replaced or other repairs must be made, the nearest service centre (see page 1) should be contacted or direct connection made with the factory.

New grinding discs, spare-parts and accessories (also at intermediate times) can be ordered from our customer service or the relevant agent.

**The grinding discs can be resharpened  
once or twice at the factory.**

**Data** such as **manufacturing number** and type of **power supply** as specified on the nameplate of the coffee grinder should be stated on orders for grinding discs, spare-parts and accessories to ensure rapid and efficient advice and delivery.

**Ditting Maschinen AG**  
Bramenstrasse 11  
P.O. Box 241  
CH-8184 Bachenbülach  
Switzerland

Phone: +41 44 864 18 00  
Fax: +41 44 864 18 01  
e-mail: [info@dittingswiss.ch](mailto:info@dittingswiss.ch)  
[www.dittingswiss.ch](http://www.dittingswiss.ch)

Subject to technical modification.